

KMG

Model K200
Gearmotor
48F AC MOTOR

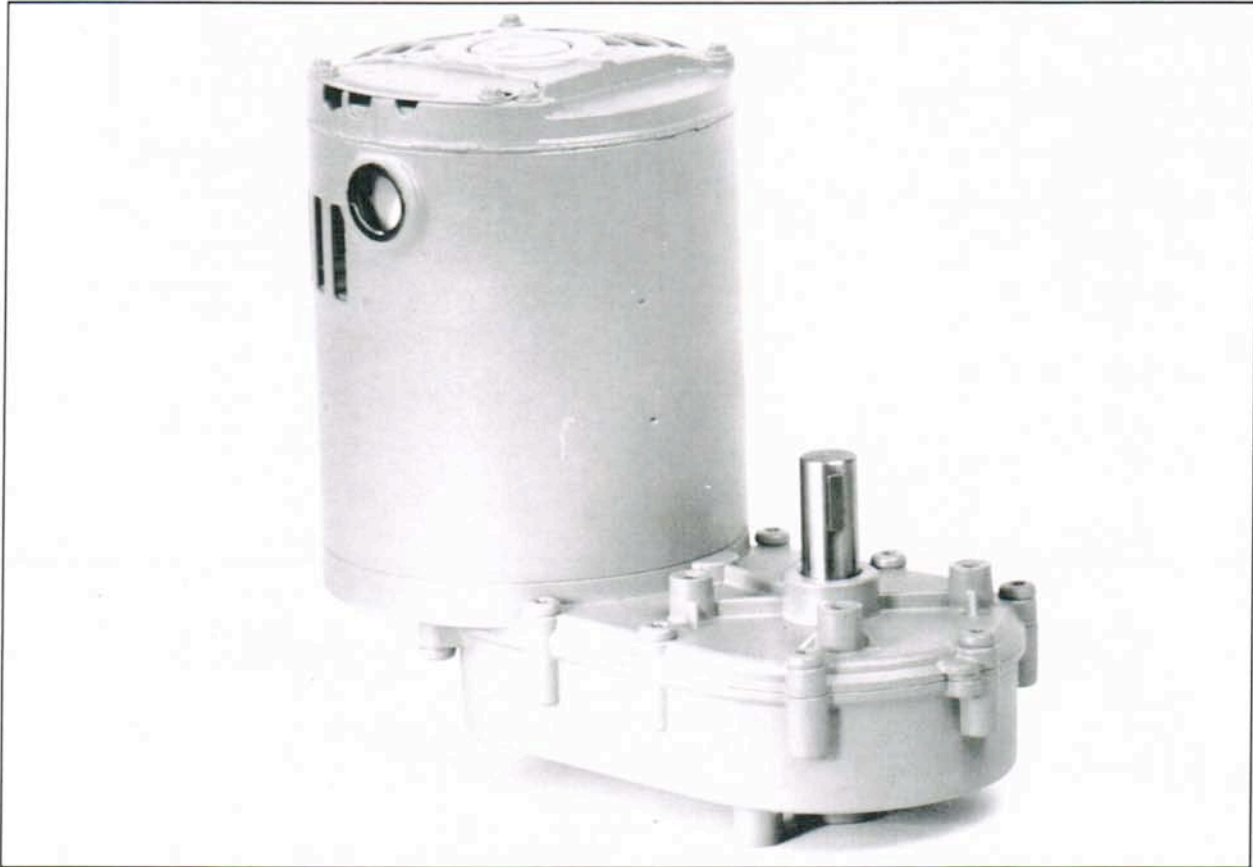

Specifications:

- 1/4 H.P. split phase motor
- 115 VAC, 60 HZ, 1 phase
- Open, continuous duty motor
- Precision helical gears in first reduction
- Two standard ratios
- Zinc diecast housing
- Ball bearing motor
- Oil impregnated bronze bearings on gear shafts
- O-Ring seal on output shaft
- Permanently lubricated
- All position mount

Options:

- Needle bearings
- Automatic thermal overload
- Double extended output shaft
- 3/4" ID hollow output shaft
- 5" dia. motor
- For other options call factory

Note: Painted finish is not standard

Model K200 48FR OPEN AC Motor

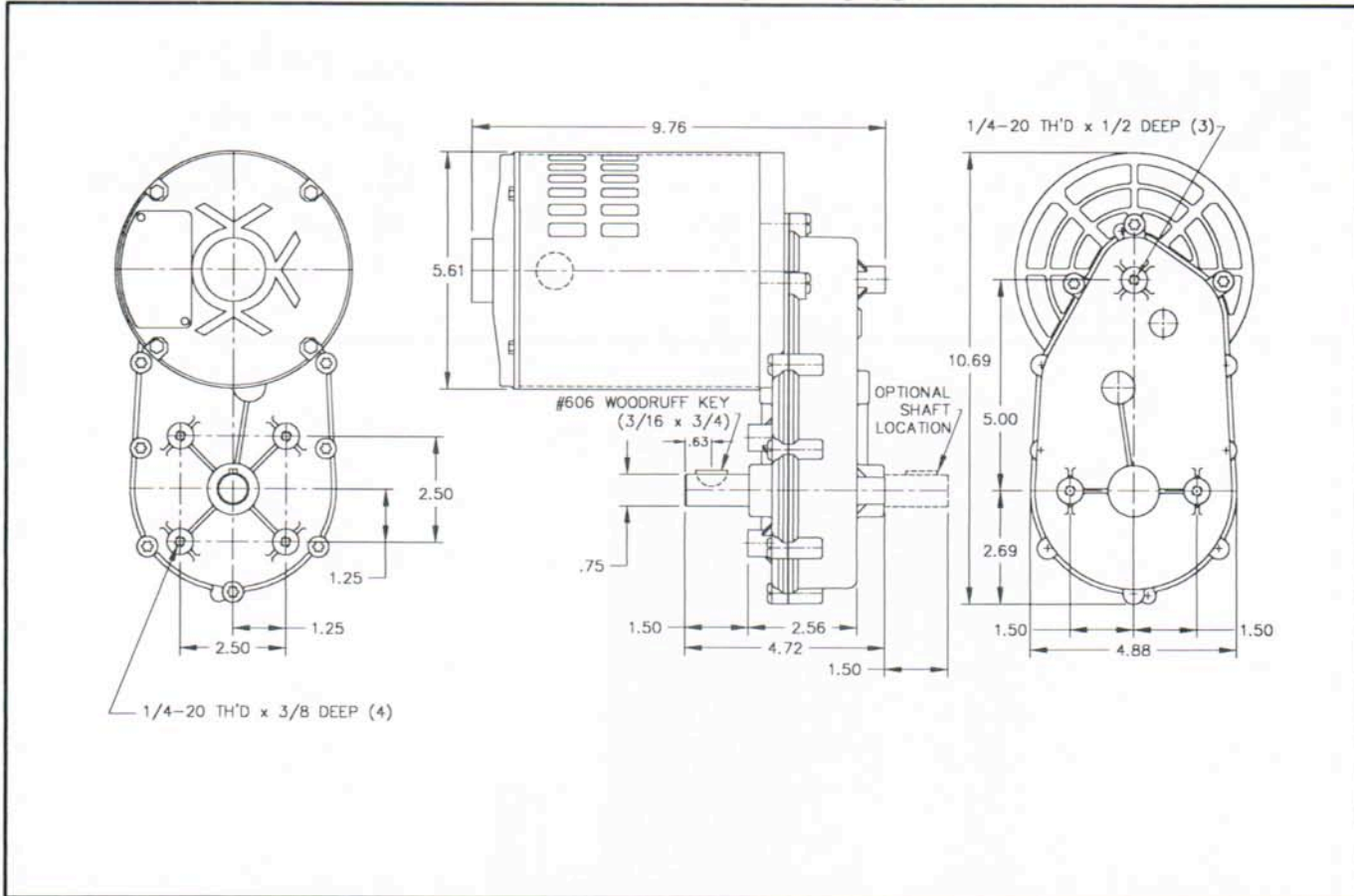

Torque Chart (inch lbs):

1/4 HP 115 VAC 60HZ
4 POLE SPLIT PHASE

RATIO	FULL LOAD RPM	FULL LOAD TORQUE
140:1	12	950
213:1	8	1450

(Output Torque is Theoretically Calculated and Gear Limited)

Overhung load capacity (.75" from output boss) not to exceed 300 lbs.



KLAUBER MACHINE & GEAR CO.
1101 GEARTECH PARKWAY
PACIFIC, MO 63069
PHONE (636) 257- 3002 FAX (636) 257- 3005