

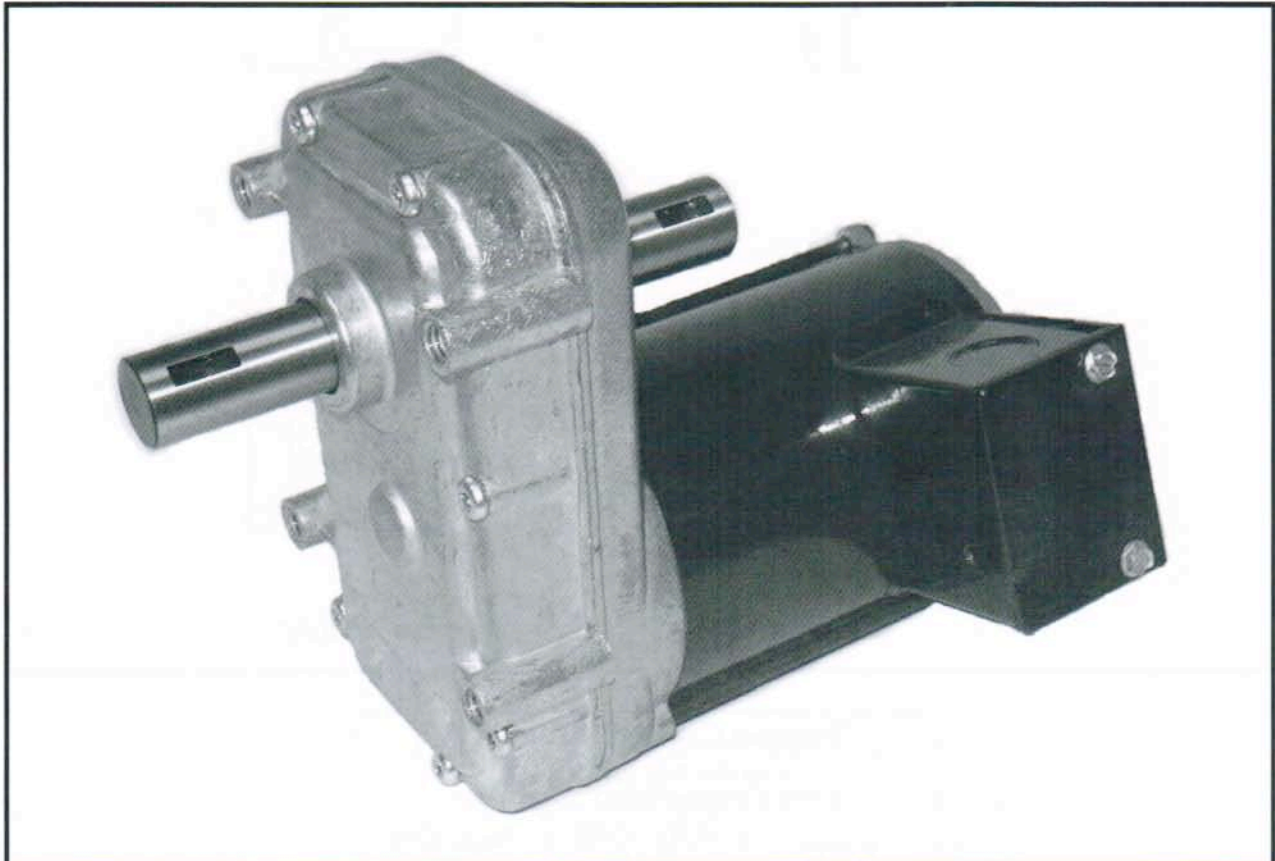

Model K300 Gearmotor 3.3" PSC Motor



Specifications:

- 1/10 hp 3.3" Permanent Split Capacitor motor
- 115/60 VAC input
- Open continuous duty motor
- Auto-reset thermal protection
- Ball bearings in motor
- Reversible rotation
- Zinc die-cast housing
- Eight standard gear ratios
- Precision helical gears in first reduction
- Oil impregnated bronze bearings on gear shafts
- O-ring seal on output shaft
- Permanently lubricated
- All position mount

Options:

- 230 VAC 50/60 Hz input
- Dual 115/230 VAC input
- Needle bearings on gear shaft
- Single extended output shaft
- Brake mounted on motor
- Consult factory for other options

Model K300 3.3" VENTED PSC Motor

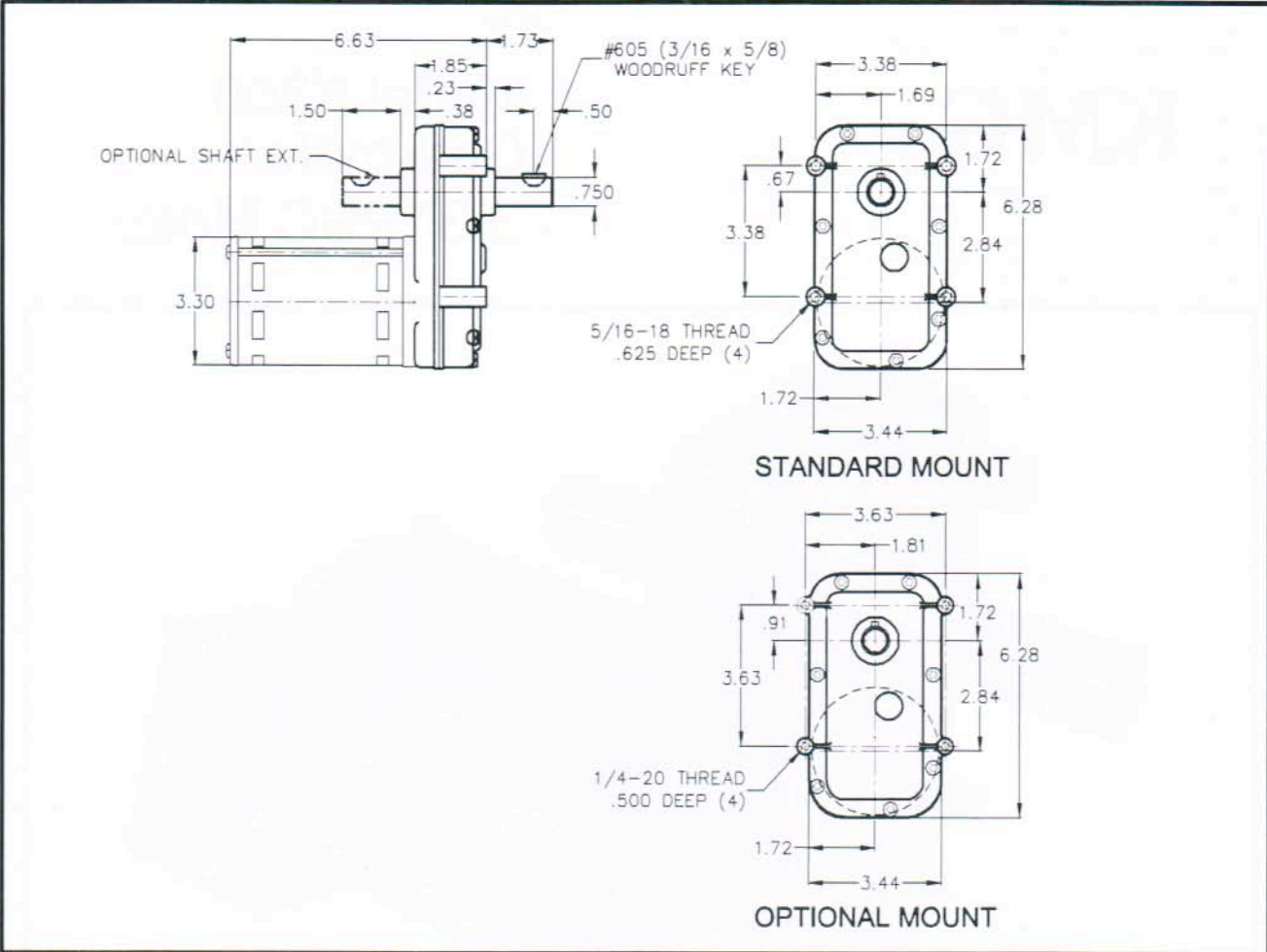

Torque Chart (inch lbs)		
1/10 HP 115 VAC /60 HZ 4-POLE PERMANENT SPLIT CAP.		
RATIO	FULL LOAD RPM	FULL LOAD TORQUE
43:1	36	140
103:1	15	300
139:1	11	405
250:1	6	600
351:1	4	600
637:1	2.4	600
903:1	1.7	600

Overhung load capacity (.75" from output boss) not to exceed 300 lbs.



KLAUBER MACHINE & GEAR COMPANY
 1101 GEARTECH PARKWAY
 PACIFIC, MO. 63069
 PH: (636) 257-3002 FAX: (636) 257-3005
www.klaubergear.com